





***Mechanical Improvements
Biosolids Processing Facility
Contract 7153***

June 20, 2018



Biosolids Processing Facility (Background)



- Construction completed in 1991
- Operated by New England Fertilizer Company (NEFCo)
- Process an average of 100 Dry Tons Per Day/Total Suspended Solids



Contract 7153 Summary

Scope: Replace the following:

- Nine of twelve Separator Conveyors
- Two Dust Collection Systems
- Dome Cover Braces (four storage tanks)
- Gas Boiler
- Nitrogen Purge Generator System
- Air Compressor System



Process Overview

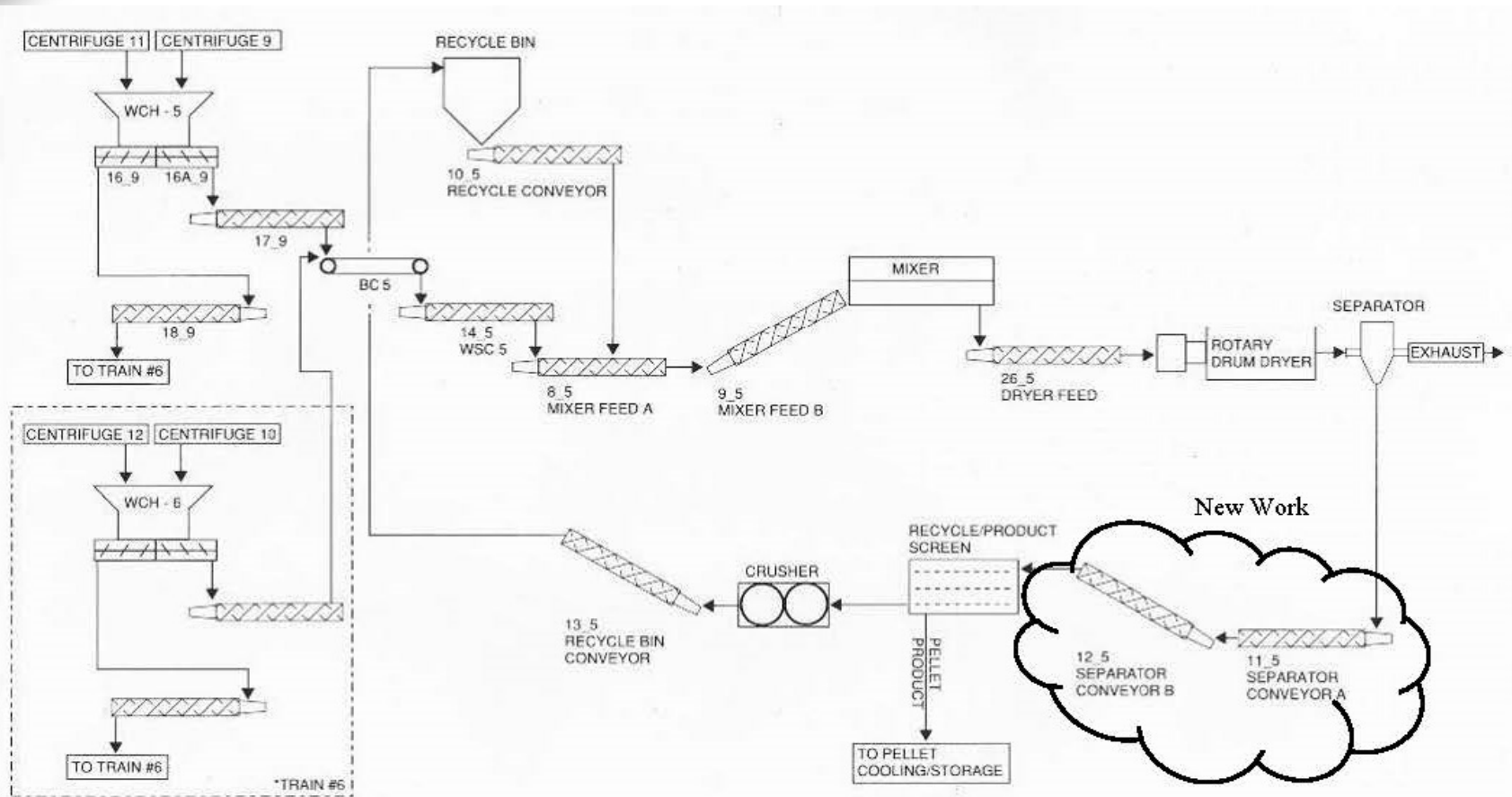



Separator Conveyor

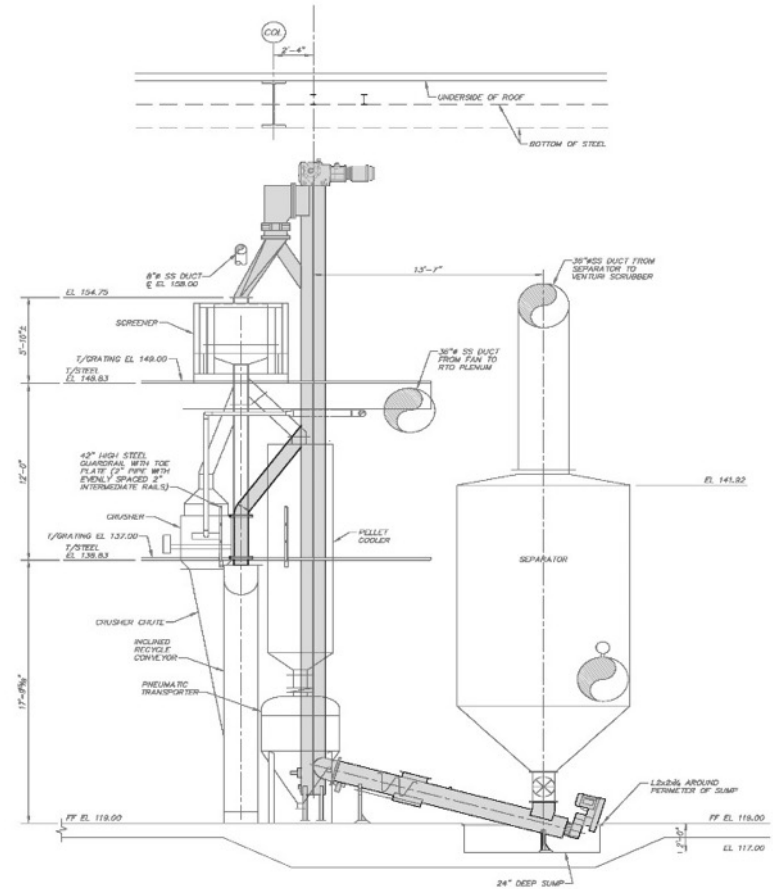



Dust Collector System

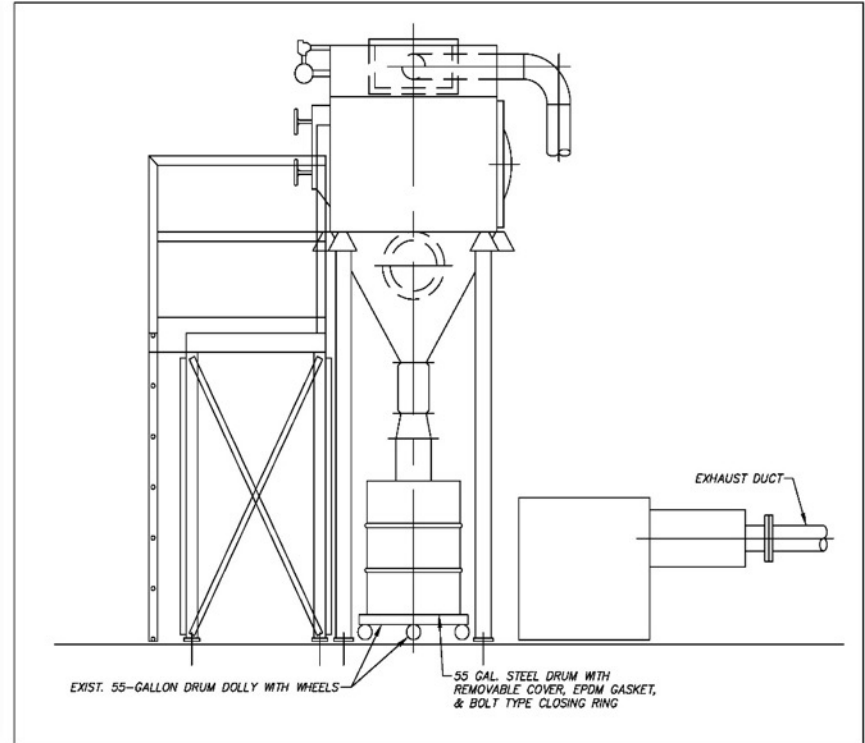



7153-Scope of Work



Sludge Tank Roof Cover
(braces under roof cover)



Gas Boiler



7153-Scope of Work



Nitrogen Purge Generator
(fire suppression system)



Air Compressor System



Contract 7153 Summary

- Contractor: Daniel O'Connell's Sons, Inc.
- Contract Price: \$2,700,000 (+15% Design/CA fee)
- Contract Duration: 420 days





***Remote Headworks and Deer Island Shafts Study
Contract 7237***

June 20, 2018



Contract 7237 Shafts Location Plan and Scope of Work

SCOPE OF WORK

- Visual inspection, probing and hammer sounding of 7 shafts and 3 connecting structures and effluent channels
- Concrete cores taken from 7 shafts for lab testing
- Ventilation evaluation
- Corrosivity analysis
- Measurement of actual shaft diameters





Ward Street, Columbus Park and Chelsea Creek Headworks

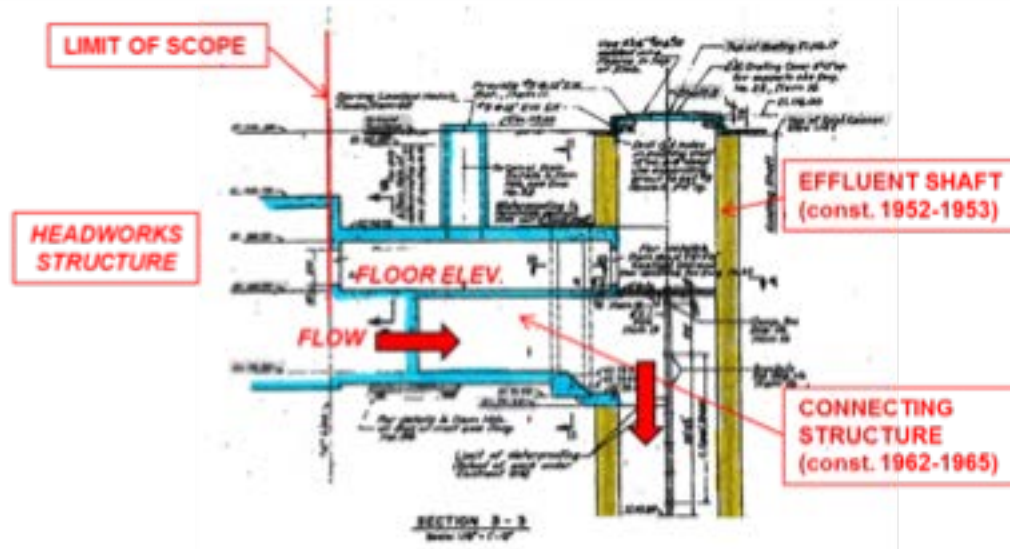

Section shown - Chelsea Creek HW (Ward Street and Columbus Park similar)

Location	Total Depth of Shaft
Ward Street - Shaft "A"	312'
Columbus Park - Shaft "B"	318'
Chelsea Creek - Shaft No. 2	295'



Ward Street, Columbus Park and Chelsea Creek Headworks



Doorway from Connecting Structure into Shaft at
Chelsea Creek Headworks



Ward Street, Columbus Park and Chelsea Creek Headworks



Deteriorated Concrete in Shaft at Chelsea Creek Headworks



Ward Street, Columbus Park and Chelsea Creek Headworks



Top of Effluent Shaft at Columbus Park Headworks



Nut Island Headworks Shaft



South System Shaft at Nut Island Headworks



Deer Island Treatment Facility Shafts



Shaft "C"



Shaft "No. 1"



Contract 7237 Procurement

- Two proposals were received on May 21, 2018

Arcadis U.S., Inc.	\$1,194,580	2,334 hours
Mott MacDonald, LLC	\$1,371,788	4,856 hours
<i>Engineer's Estimate</i>	<i>\$802,010</i>	<i>3,878 hours</i>

- Contract Start: July 2018
- Duration: 10 Months





***Chelsea Creek Headworks Upgrade
Contract 7161 - Change Order 14***

June 20, 2018



Chelsea Creek Headworks: Exterior Walls As Found





Chelsea Creek Headworks: Masonry Repairs





Chelsea Creek Headworks: Masonry Repairs





Chelsea Creek Headworks: Masonry Repairs





Chelsea Creek Headworks: Masonry Repairs





Chelsea Creek Headworks: Masonry Repairs





Chelsea Creek Headworks: Masonry Repairs





Chelsea Creek Headworks: Temporary Roofing





Chelsea Creek Headworks: New 480V Electrical Service





Chelsea Creek Headworks: New Exterior Siding







***Marlborough Maintenance Facility
Contract 6650B, Change Order 10***

June 20, 2018



Building Entrance

Pre



Current





Silo Ash Silos – Converted to Covered Storage

Soda Ash Storage



Covered Storage





CO2 Tanks Removed – Future Parking Area





CO2 Room – Converted to Plumbing Shop





Fluoride Room Converted to SCADA Room

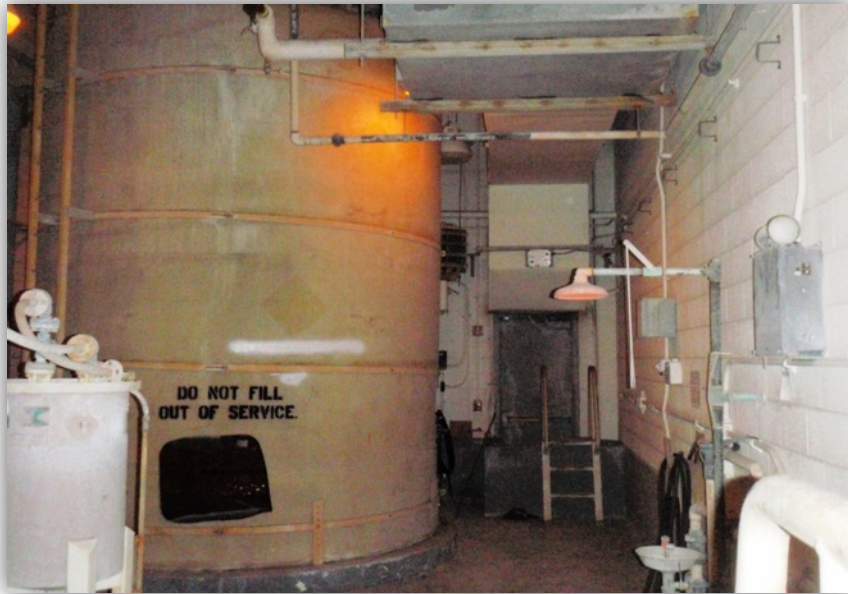



Portion of Pump Room Converted to Mechanical Shop





Portion of Pump Room Converted to Electric Shop





Mechanical Equipment Room Updated





Portion of Mechanical Equipment Room Now Break Room





Change Order No. 10 – Concrete Curbing

- Original Design in 2007
- Part of three Projects
- Section of Concrete Curb Deemed to be in Good Condition now in need of replacement
- Deteriorating Condition - Unforeseen
- Cost of \$29,346

